

WuduMate Anti-Ligature Tap



UNICLASS L721:N5352	EPIC H12:Y3107
CI/SfB (74.2)	(U35)

(RIBA CLASSIFICATION)

Specification Sheet (Metric)



Illustrated

WuduMate Anti-ligature Tap
Product Code: WM-T-AL

Weight

Gross: 0.45kg

Material

316 Stainless Steel Body

Finish

Brushed

Flow Rate

5 LPM
Minimum pressure 1BAR

Installed with

Wudumate Classic
On it's own

Frequent Applications

Residential • Municipal • Education • Healthcare • Offices • Mosques

Associated Products

Additional TMV required
Separate Sensor

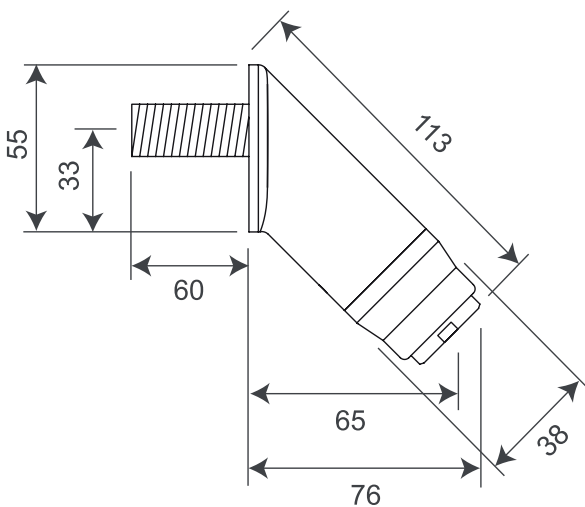

All dimensions in mm

The information in this specification sheet reflects the current technical specifications at the time of print. We reserve the right to change the technical or physical specifications without prior notice. All WuduMate images and symbols are exclusive property of Specialist Washing Co. Specialist Washing Co. accept no liability for loss or damage caused by improper installation. Any reproduction or retransmission or republication of any part of this specification sheet is strictly prohibited, unless prior written permission has been granted by Specialist Washing Co, E&OE.

WuduMate



+44 (0)1784 748080 • info@wudumate.com