

WuduMate Acrylic



COMPACT

WM-COM-A

CSA Certification No: 301439

Specification Sheet

Imperial & Metric



Also available in Black & White

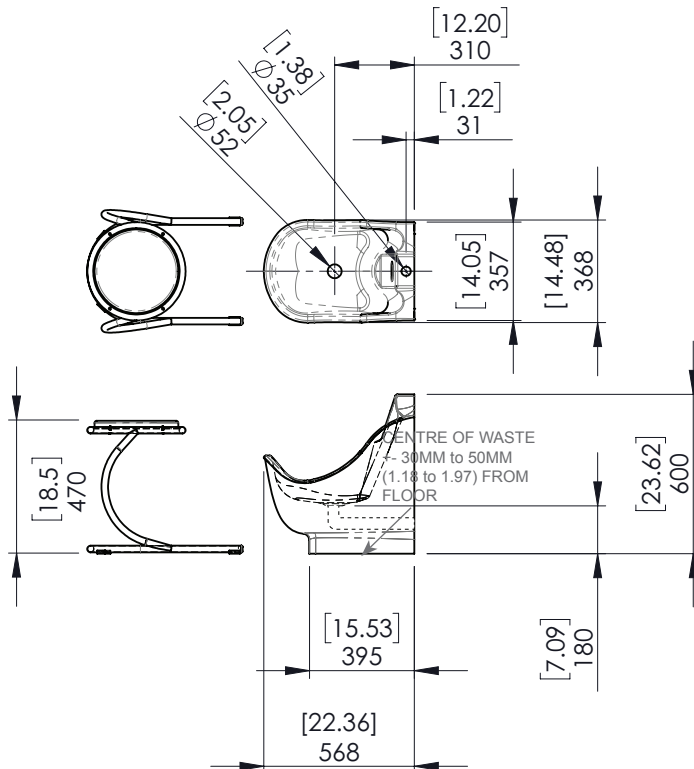

All dimensions in mm & Inches

The information in this specification sheet reflects the current technical specifications at the time of print. We reserve the right to change the technical or physical specifications without prior notice. All WuduMate images and symbols are exclusive property of Specialist Washing Co. Specialist Washing Co. accept no liability for loss or damage caused by improper installation. Any reproduction or retransmission or republication of any part of this specification sheet is strictly prohibited, unless prior written permission has been granted by Specialist Washing Co, E&OE. DEC2020

UNICLASS L721:N5352	EPIC H12:Y3107
CI/SfB (74.2)	(U35)

(RIBA CLASSIFICATION)

Description

Wudu unit for use in the home and/or where space is limited.

Illustrated

WuduMate Compact Acrylic

Material

Unit: sanitary-grade reinforced acrylic

Seat: chromed steel

Included

WuduMate Compact bowl, stool, tap & fittings

Colour

White (WM-COM-A-WHT) as standard

Black & white (WM-COM-A-B/W) on request

Weight / Size

Net: 16.8kg 37lbs
Gross: 19.8kg 43lbs 10oz

Carton Size (mm) / inches
(450W) x (640L) x (620H)
17.71W x 25.20L x 24.41H

Accessories/Options

- WuduMate Compact Taps
 - Manual Lever Monobloc Tap
 - Manual Lever Pillar Tap Round / Square
 - Pillar Tap Round / Square
 - Pillar Tap Square with Lever
 - Sensor Tap
- Aerators
- Thermostatic Mixing Valve (TMV3)
- Seat Handles
- Shaped Anti-Slip Matting
- Range of Wudu signage
- Waste

Frequent Applications

Residential • Municipal • Education • Healthcare • Offices.
Where space is limited.

Special Notes

'Water-in' and 'waste-out' through either floor or rear of the unit, negating the need for sub-floor access.

Associated Products

WuduMate Compact Porcelain

WuduMate Classic for medium use applications, including prayer rooms and multifaith rooms in commercial buildings.

WuduMate Modular for high usage areas, including Mosques.

Wudumate Mobile for moveable wudu appliances.

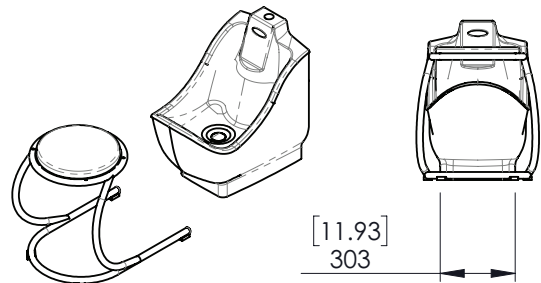

WuduMate



+44 (0)1784 748080 • info@wudumate.com